

Tripod agitator for drums

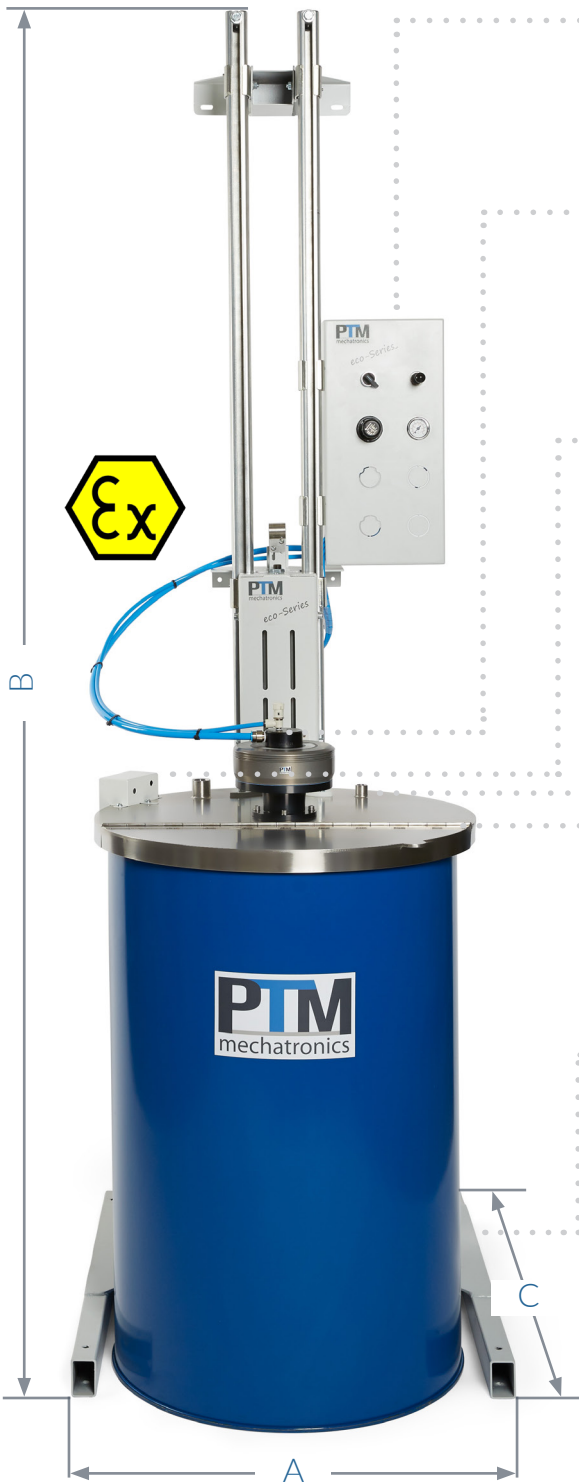

Control panel with safe two-hand operation optional

Agitator with ATEX zone separation flange
 Ex II 1/2 G Ex h IIC T6 Ga/Gb X
 Ex II 1/2 D Ex h IIIC T85°C Da/Db X

Container recognition with agitator switch-off optional

Mounting options for suction lances, probes, temperature sensors etc. optional

Stainless-steel lid with inspection flap and safety grid

Equipped with ESD castors optional

Standard sizes
 Individual dimensions possible.

eco-Station	Art. No.	Lifting height	Container type	A	B	C
eco-Station 30	5051	500	20-60l	440	1335	600
eco-Station 100	5160	700	100	550	1746	700
eco-Station 200	5052	1000	200l	700	2344	800

All dimensions in mm.

WE GENERATE MOVEMENT IN SPECIAL ENVIRONMENTS.

Dimensions (in mm)

ECO-STATION
30L

ECO-STATION
100L

ECO-STATION
200L

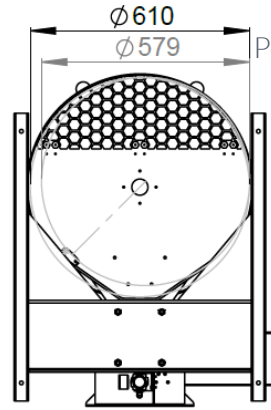
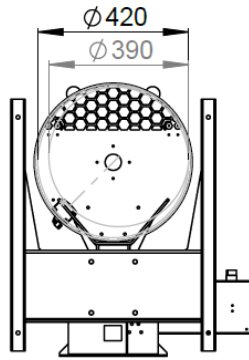
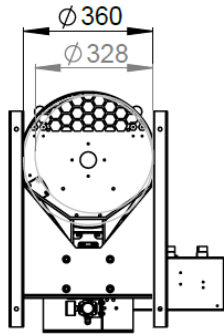

Possible barrel diameter
min. and max.

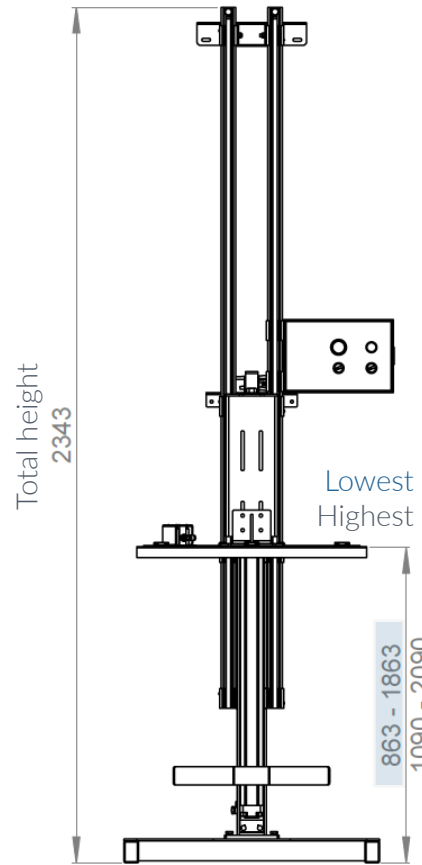
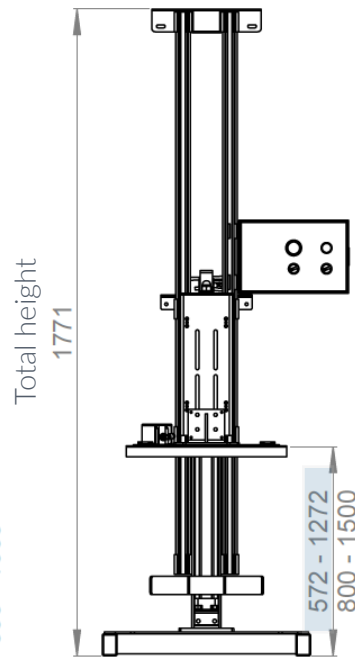
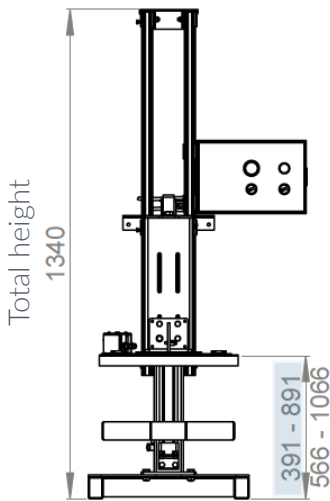

Lowest possible travel path
Highest possible travel path

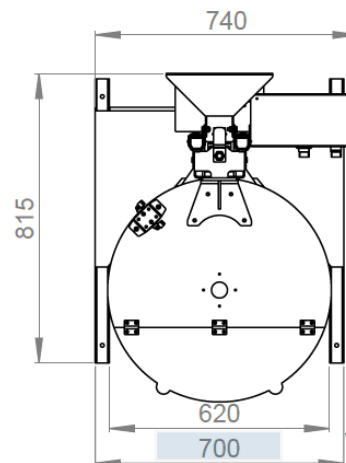
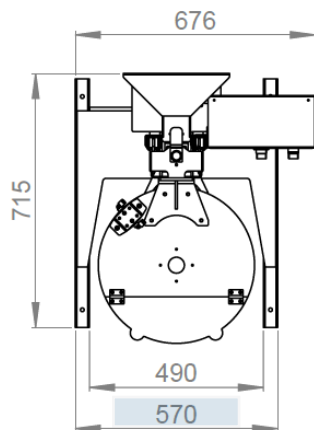
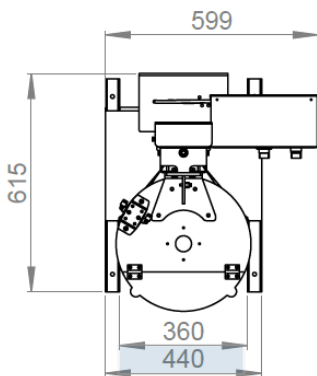

Total width

Max. barrel width
Width without control panel

WE GENERATE MOVEMENT IN SPECIAL ENVIRONMENTS.