

**Drive and stirring technology for**

FOOD | PHARMA | COSMETICS | CHEMICALS | AUTOMATION

**PTM**  
mechatronics

## **Operating instructions** for

eDRIVE 1200 | eDRIVE 1600

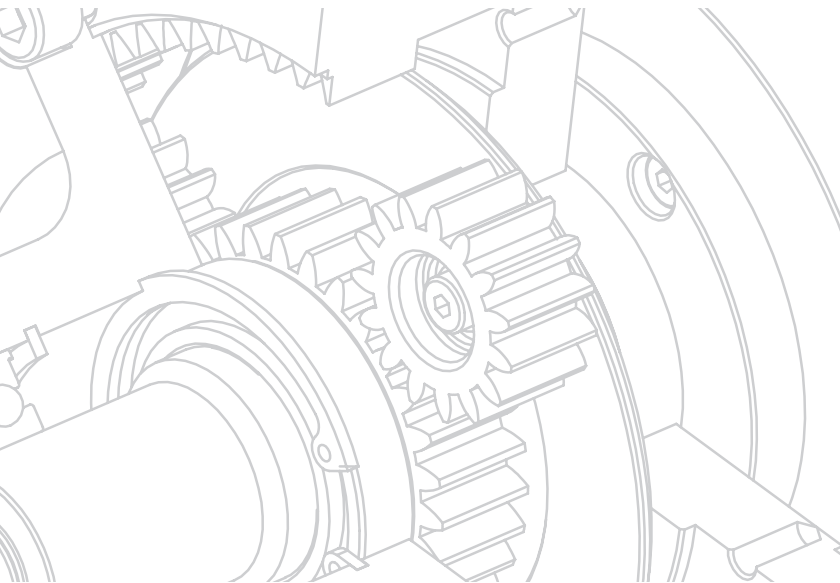

**WE GENERATE MOVEMENT IN SPECIAL ENVIRONMENTS.**

The logo for PTM mechatronics features the letters 'PTM' in a bold, sans-serif font. The 'P' and 'M' are black, while the 'T' is a vibrant blue. Below this, the word 'mechatronics' is written in a smaller, black, lowercase sans-serif font. The background of the entire page is a technical line drawing of a mechanical assembly, with a prominent blue wireframe grid that curves across the scene from the top left towards the bottom right.

**PTM**  
mechatronics

FULL SERVICE PROVIDER  
FOR DRIVE AND STIRRING  
TECHNOLOGY.

## INHALTSVERZEICHNIS

1. Preface	2
2. General information	3
3. Manufacturer and customer service	4
4. Safety and operator obligations	4
5. Intended use	5
6. Transport and storage	6
7. Electrical work	7
8. Mechanical installation	8
9. Electrical installation	9
10. Commissioning	12
11. Maintenance and repair	13
12. Technical data	15
13. Elimination of malfunctions	15
14. Disposal	16
15. Explosion protection	16
16. Certificates	18

## 1. Preface

Dear reader,

Thank you for choosing a product from PTM mechatronics GmbH.

Our drive and stirring technology products are manufactured with the highest quality and the latest manufacturing processes.

Our service covers the entire value chain of your product, from advice and quotation through development and production to a reliable after-sales service. In addition to our standard range, your customer-specific requirements are also in the best of hands with us.

We have a certified quality management system according to **ISO 9001: 2015**. For the independent manufacture and sale of ATEX-certified products, we also have a certified quality management system in accordance with **ISO / IEC 80079-34: 2018-08**. We offer you maximum safety in all potentially explosive environments including **ATEX zone 0**.

We attach particular importance to being able to accompany and support you in all areas relating to drive and agitator technology. That is why we have specialized in our core industries of chemicals, food, pharmaceuticals, cosmetics and automation with our technologies and know-how: **ATEX, stainless steel, food safety, clean rooms, protection class IP68 and more.**

If you would like to find out more about our service or our products, please contact us or visit our website at: **[www.ptm-mechatronics.com](http://www.ptm-mechatronics.com)**.



## 2. General information

### 2.1. Use of the documentation





These operating instructions are the original operating instructions.

These operating instructions are part of the drive. It is intended for everyone who works on the drive.

Provide these operating instructions in a legible condition near the drive. All operators and users of the drive as well as persons who work independently on the drive must have read and understood the operating instructions in full. Due to the different sizes and equipment variants, the illustrations shown in these operating instructions may differ from your drive. If you have any questions, please contact the PTM mechatronics GmbH customer service.

### 2.2. Notes

The following symbols are used in the operating instructions:

	General instructions.
	Danger high voltage.
	Warning of hot surfaces.
	Warning of automatic start.
	Observe and apply additional information in external documentation.

### 2.3. Warranty claims

Make sure that these operating instructions are read before any work on or with the drive. This is the prerequisite for trouble-free operation of the drive and the existence of any warranty claims.

## 2.4. Product names and trademarks

The product names mentioned in this documentation are trademarks or registered trademarks of the titleholders.

## 2.5. Copyright notice

The copyright lies with PTM mechatronics GmbH. The unauthorized duplication, processing, editing or distribution, as well as any other kind of exploitation is prohibited.

## 3. Manufacturer and customer service

PTM mechatronics GmbH  
Gewerbepark 1  
D-82281 Egenhofen, Germany  
Phone: +49 8134 - 25 797 - 0  
Fax: +49 8134 - 25 797 - 99  
Email: [info@ptm-mechatronics.com](mailto:info@ptm-mechatronics.com)  
Internet: [www.ptm-mechatronics.com](http://www.ptm-mechatronics.com)

If, despite all the care, your product does not meet your requirements, please do not hesitate to contact us.

Please always contact our customer service department before you send a drive back to us so that we can correctly assign your process. Please have the device number ready for this.

## 4. Safety and operator obligations

Operators and users must familiarize themselves with the drive and its possible applications before commissioning. The operating instructions enable safe and efficient operation of the drive. You should therefore ensure that the operating instructions are read in full by all operators and users before commissioning the drive. The instructions must be strictly adhered to during operation.



Please also read and observe the operating instructions from the drive manufacturer.

Certain work may only be carried out by qualified specialists. These are in particular:

- Assembly and installation
- Connection and commissioning
- Maintenance and repair
- Decommissioning and dismantling

Please also note the following:

- RL 1999/92 / EG (health and safety of workers)

- general safety regulations and local occupational health and safety regulations
- Warning notices on the drive
- Do not start up damaged drives



Please observe the accident prevention regulations and any additional safety provisions and regulations of the respective country!

## 5. Intended use

The drives are used to drive agitator shafts and agitator elements (e.g. to stir up and mix liquids and powders in open or closed containers), Axes or similar. These are generally referred to in the operating instructions as "drive / s". For safe operation, they must be firmly connected to a housing or mounted on the lid of a container or on a drum lid lifting device. When installing the drive in electrical systems or machines, all local laws and guidelines for the system or machine must be observed before use.

### 5.1. General

The drives are only approved for proper and intended use. Any infringement or manipulation of any kind on the drives will void the guarantee and the manufacturer's responsibility.

Therefore, please note the following:

- The speed ranges of the drives must be adhered to.
- The environmental conditions specified in the operating instructions must be observed.
- When using add-on parts, such as the agitator shaft and impeller, the operator must ensure that these are properly installed.

### 5.2. Additional information for the use in Ex areas

The drive can be used in the following potentially explosive areas:

- as zone separation between zone 0 and zone 1
- zone 1
- zone 21
- zone 2
- zone 22

Please note the following requirements for use in Ex areas:

- The drive may only be put into operation in potentially explosive environments by trained specialist personnel.
- The operator must ensure that there are no foreign bodies in the stirring container that could cause sparks during operation.

- When electrostatically charged parts are discharged, ignitable sparks can occur. Dangerous electrostatic charges from mixing liquids or bulk solids must be avoided.
- Protect the drives from falling objects.
- The use of the drives is only permitted if the housing is completely closed and undamaged.
- The use of damaged drives is not permitted.
- Reduce the number and selection of removable connections to a minimum. Keep cables as short as possible and avoid mechanical tension.
- Only accessories that meet all the requirements of the European directives and the respective national legislation may be used in potentially explosive areas.
- A direct dangerous electrostatic discharge on the equipment is not permitted. Normally, such discharges cannot be generated by humans, but require a compressed air nozzle or the like.
- When used in dust-ex areas, the national regulations and operator guidelines must be observed with regard to minimum ignition energy.
- Lightning protection measures are to be ensured by the operator.
- When stirring in non-conductive containers, please observe the operator guidelines, national regulations and data sheets for the media to be stirred. Inerting may be necessary or conductive additives have to be added. These measures are to be carried out by the operator.
- The drive is mechanically designed for pass-through operation. Furthermore, it can be operated in dry or idle mode. Please note the operator guidelines, national regulations and data sheets for the media to be stirred. When using the agitator in pass-through operation, the risk of ignition of mechanically generated sparks must be considered and safely avoided.
- When dimensioning the shaft, ensure that there is sufficient distance from the container wall to prevent the shaft from coming into contact with the container.
- Make sure that no heat can arise from a chemical reaction between two media.
- Impact processes involving rust and light metals with their alloys can form ignitable sparks. Therefore, do not use tools with corroded surfaces.
- When selecting materials and fastening accessories, take corrosion, wear and other interactions into account.
- Further hazards when using the drive for an agitator must be determined by the manufacturer. The resulting ignition hazards must be reduced by taking appropriate explosion protection measures.
- A limited temperature range of  $-10\text{ ° C} \leq T_a \leq +40\text{ ° C}$  applies.

## 6. Transport and storage

The drive is delivered in cardboard packaging and is protected by it. Make sure that it does not get damaged. On receipt, check the drive for completeness and transport damage. Note any obvious transport damage on the shipping documents and have this acknowledged by the



carrier. In the event of hidden transport damage, please contact us with the relevant documentation of the damage and the device number. If the drive is obviously damaged, it must not be assembled, installed or put into operation.

Please note the following conditions for storage:

- Store in a dry place
- Protect from shocks
- Storage temperature: 10 ° C to 40 ° C

After long periods of storage, check the condition of all parts before use:

- Corrosion on drive and components
- Embrittlement, hardening, cracking of seals
- Penetration of moisture and dirt

Before commissioning, completely remove storage residues or replace damaged parts. Please note the information under „4. Safety and operator obligations“.



## 7. Electrical work

### 7.1. Safety in electrical work

Please note the following when doing electrical work during installation or maintenance:

- Electrical work may only be carried out by trained electricians
- Observe the following safety rules:
  - Unlock
  - Secure against restart
  - Determine all-pole absence of voltage
  - Ground and short-circuit
  - Cover or protect neighbouring parts under voltage
- Dangerous voltages occur at all power connections and connected terminals and cables when the device is switched on, even when the motor is at a standstill.

### 7.2. Electrical connection

	Please observe the information on the electrical connection in the operating instructions of the drive manufacturer.
	Please note the information under „9. Electrical installation“.

## 8. Mechanical installation

### 8.1. General notes



The surface temperature can exceed 60°C during operation.  
Do not touch. Let cool down before touching.

Any monitoring and protective equipment must also be in operation during a trial run. Make sure that the protective devices correspond to the current hazard potential of the application and are functional.

During operation, attention must be paid to hot surfaces and moving, bare or live parts. Any transport locks must be removed before operation.

If there are any deviations from the normal functioning of the drive during operation, it must be switched off. These include unusual noises, increased temperature or unusual vibrations. Before restarting, the cause must be determined and eliminated. If you have any questions, please contact our customer service under „3. Manufacturer and customer service“.

Disconnect the drive from the power supply prior to any inspection or revision.

Close and screw the terminal box before connecting the power supply.

Motors with a backstop must never be operated for a longer period of time at or below the speed at which the sprags rub against the inner and outer ring due to the insufficient centrifugal forces.

### 8.2. Assembly

During assembly, the information on the nameplate is decisive. Please always observe the safety instructions under „4. Safety and operator obligations“

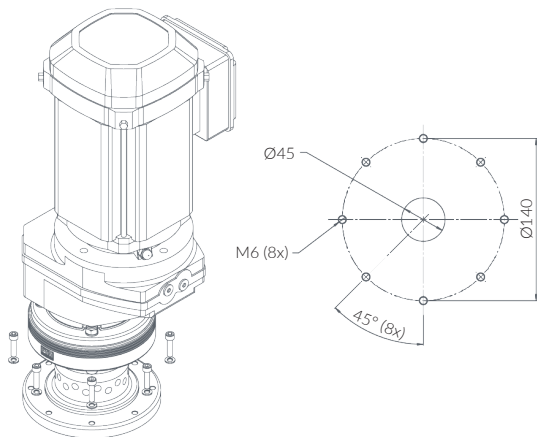

- Check whether the information on the nameplate corresponds to the voltage network or the output voltage of the inverter.
- Check the drive for damage.
- Check the drive for remaining transport locks.
- Check the ambient temperature using the nameplate (also on the transmission) and make any necessary adjustments.
- Provide a neutral environment without oils, acids, gases, vapors, radiation, etc.
- The installation height is measured at a maximum of 1000m above sea level.
- Note the restrictions for the encoder.
- Observe the information on mechanical installation in the appendix to the operating instructions in the case of an FS logo on the nameplate.
- Before installation, clean the cover to ensure that the drive is securely positioned.

- Place the drive on the lid / the housing / the drum lid lifting device, align it centrally and fix it with eight screws.



## 9. Electrical installation

### 9.1. General notes

	<p>Electric shock due to incorrect installation! Death or serious injuries.</p>
	<p>The agitator drive is to be integrated into the equipotential bonding.</p>

- Use switch contacts of utilization category AC-3 according to EN 60947-4-1 to switch the motor.
- To switch the brake, use switching contacts that, depending on the type and design of the brake, correspond to the following utilization categories:
  - Switching contacts for the supply voltage when operating with alternating voltage

- (AC): AC-3 according to EN 60947-4-1 or AC-15 according to EN 60947-5-1.
- Switching contacts for the supply voltage when operated with direct voltage (DC): Preferably AC-3 or DC-3 according to EN 60947-4-1, alternatively contacts according to utilization category DC-13 according to EN 60947-5-1 are also permitted.
  - Switching contacts for the optional DC isolation: AC-3 according to EN 60947-4-1.
- In the case of converter-fed drives, observe the corresponding wiring instructions in the operating instructions for the frequency converter.

## 9.2. Connection diagrams and allocation plans

Please note the attached wiring diagrams when connecting the motor. A connection without a connection diagram is not permitted.

## 9.3. Wiring instructions

Please note the safety instructions under „4. Safety and operator obligations“ and „9.1. General notes“.

In order to prevent a malfunction of the brake control, brake cables must always be laid separately from other unshielded power cables with clocked currents. Power cables with clocked currents are in particular:

- Output lines from frequency and servo converters, soft starters and braking devices
- Supply lines to braking resistors, etc.

In the case of mains-operated motors and the use of cut-off in the DC and AC circuits, the connection between the brake rectifier and the external contactor contact must be made in a separate power cable separate from the motor voltage supply.

To protect against a malfunction of the motor protection devices:

- separately shielded supply lines can be laid together with clocked power lines in one cable.
- unshielded supply lines are not laid together with clocked power lines in one cable.

## 9.4. Special particularities when operating with a frequency converter



Please note the information in the attached operating instructions from the drive manufacturer.

## 9.5. External earthing on the terminal box, LF earthing



Please note the information in the attached operating instructions from the drive manufacturer.

## 9.6. Improvement of the grounding (EMC), HF grounding



Please note the information in the attached operating instructions from the drive manufacturer.

## 9.7. Special particularities in switching operation



Please note the information in the attached operating instructions from the drive manufacturer.

## 9.8. Special particularities of rotating field magnet motors



Please note the information in the attached operating instructions from the drive manufacturer.

## 9.9. Notes on connecting the motor

It is essential to take into account the valid wiring diagram! If the circuit diagram is not available, the motor must neither be connected nor put into operation. You can obtain the valid circuit diagram free of charge from our customer service under „3. Manufacturer and customer service“



Danger from contamination in the terminal box! Death or serious injuries.

- Seal the terminal box and any openings for cable entry that are not required in a dust-tight and waterproof manner.
- Remove any foreign bodies, dirt and moisture from the terminal box.

Please also note the following points when connecting the motor:

- Check the cable cross-section
- Correct arrangement of the terminal bridges
- Fixed screw connection of the connections and protective conductor
- Connection cables are exposed to prevent damage to the cable insulation
- Compliance with clearances, see „7.2. Electrical connection“.
- In the terminal box: check winding connections and tighten if necessary

- Connect according to the enclosed circuit diagram
- Avoid protruding wire ends
- Connect the motor for the prescribed direction of rotation

## 10. Commissioning

- During installation, please always observe the instructions under point „4. Safety and operator obligations“.
- In the event of problems, please refer to point „13. Elimination of malfunctions“.

If the motor contains functionally safe motor components, the following safety information must be observed:



Disable safety device! Death or serious injuries.

- All work on functional safety components may only be carried out by trained specialist personnel.
- All work on functional safety components must strictly follow the specifications in these operating instructions. In the event of non-compliance, the warranty claim is void.



Please also note the information in the attached operating instructions from the drive manufacturer.



Electric shock due to incorrect installation! Death or serious injuries.

- Use switch contacts of utilization category AC-3 according to EN 60947-4-1 to switch the motor.
- For inverter-fed motors, observe the corresponding wiring instructions in the operating instructions for the frequency inverter.



The surface of the drive can reach high temperature during operation. Risk of burns.

- The drive must cool down before any work.



The specified maximum limit torque ( $M_{pk}$ ) and the maximum current ( $I_{max}$ ) must not be exceeded, not even during acceleration processes.

- The possible consequence is damage to the operating system. Limit the maximum current at the converter.



Limit the maximum speed on the converter. Please refer to the operating instructions of the converter.



When using drives with brakes and encoders, note the comments in the operating instructions of the drive manufacturer.



Before commissioning, observe the points to be ensured in the operating instruction of the drive manufacturer.

## 11. Maintenance and repair

### 11.1. General notes



Warning of automatic start. Death or serious injury.

- Disconnect the drive and all connected components from the power supply before starting work on the drive.
- Make sure that the drive cannot be switched on unintentionally.



Inhalation, swallowing of brake debris when opening the brake.  
Irritation of the respiratory tract and organs.

- Wear a class FFP2 respirator.
- Use suitable means to clean the drive from brake debris.
- Avoid whirling up brake abrasion.

- Make sure the area is well ventilated.



The surfaces of the drive can reach high temperature during operation. Risk of burns.

- The drive must cool down before any work.

At temperatures below 0 ° C, the shaft sealing rings can be damaged during assembly. You should therefore ensure an ambient temperature of over 0 ° C.

Before assembly, coat the shaft sealing rings in the area of the sealing lip with a grease deposit.



Observe the relevant information in the operating instructions of the drive manufacturer with regard to the lubricants to be used.

To replace friction disks, contact our customer service under „3. Manufacturer and customer service“.



Do not carry out repairs or changes to the drive yourself. Contact our customer service under „3. Manufacturer and customer service“.

Make sure that all instructions have been observed before switching the motor on again. Carry out a test report for this or make appropriate markings on the motor.

Always carry out a safety and function check after all maintenance and repair work (thermal protection).

## 11.2. Inspection and maintenance intervals



Observe the specified intervals in the operating instructions of the drive manufacturer.

## 11.3. Maintenance and repair work



Carry out the inspection and maintenance work specified in the operating instructions of the drive manufacturer. Please note the corresponding safety instructions.



#### 11.4. Seals and shaft seals

Seals and shaft seals are wearing parts. The factors that have an unfavorable influence on wear are the operating hours and the speed. Other factors that promote wear include environmental conditions such as temperature, dust, solvents and vapors.

The operator is responsible for assessing wear. If necessary, the seals and shaft seals must be replaced.

#### 11.5. Transmission ventilation

The function of the vent valves is impaired by dust and dirt. This can result in damage to the gear unit. You should therefore check the function of the vent valve at regular intervals and replace it if necessary. If there is a lot of dust and dirt in the area, use a ventilation filter instead of the ventilation valve.



Please observe the information in the operating instructions of the transmission manufacturer.

### 12. Technical data

Ex marking gas	II 1/2 G Ex h IIC T5 Ga/Gb
Ex marking dust	II 1/2 D Ex h IIIC T100°C Da/Db
CE marking	CE 0408
Ambient temperature	-10°C bis + 40°C



Also note the technical data on the drive nameplate and in the drive manufacturer's operating instructions.

### 13. Elimination of malfunctions

#### 13.1. General notes



Changes of any kind to the drive and its attachments are not permitted and will invalidate the liability for defects.



Warning of automatic start. Death or serious injury.

- Disconnect the drive and all connected components from the power supply before starting work on the drive.
- Make sure that the motor cannot be switched on unintentionally.



The surfaces of the drive can reach high temperatures during operation. Risk of burns.

- The drive must cool down before any work.



Improper troubleshooting can damage the drive. Possible damage to the drive system.

- Use only original spare parts. To do this, contact our customer service under „3. Manufacturer and customer service“.

### 13.2. Störungen an Antrieb oder Anbauten



In case of malfunctions, observe the drive manufacturer's operating instructions.

## 14. Disposal

Please dispose of the packaging and used parts in accordance with the regulations of the country in which the drive is installed.

## 15. Explosion protection

### 15.1. Basics

When using the drive in potentially explosive areas, the following EU directive is decisive for the development of the product:

European explosion protection directive: 2014/34/EU

The identification of the non-electrical equipment is:

## 15.2. Explosion protection regulations

The operator must observe a number of regulations for equipment in potentially explosive areas. The following list gives an overview of the main regulations.

The following apply within the European Union:

- Directive 1999/92 / EC on minimum requirements for improving the protection of health and safety of workers who may be endangered by explosive atmospheres
- DIN EN 60079-0 on electrical equipment for potentially explosive areas - General provisions
- DIN EN 60079-10 on potentially explosive areas - Part 10-1: Classification of potentially explosive areas
- DIN EN 60079-14 on electrical equipment for areas with a risk of gas explosion - Part 14: Electrical systems in areas with a risk of explosion
- DIN EN 1127-1 on explosive atmospheres - Explosion protection - Part 1: Fundamentals and methodology
- DIN EN ISO 80079-36 Non-electrical devices for use in potentially explosive areas - Part 1: Basics and requirements
- DIN EN ISO 80079-37 Non-electrical devices for use in potentially explosive areas - Part 5: Protection through structural safety "c"



Additional national and international regulations and guidelines may also apply.

## 15.3. Zone classification for potentially explosive areas

Hazardous areas are areas in which, due to the local and operational conditions, an explosive atmosphere can occur in dangerous quantities. They are divided into several zones.

The following applies to areas at risk of explosion due to flammable gases, vapors or mists:

- Zone 0/20 - includes areas in which a dangerous, explosive atmosphere is present continuously or for a long time.
- Zone 1/21 - includes areas in which a dangerous, explosive atmosphere is to be expected occasionally.
- Zone 2/22 - includes areas in which it is to be expected that a dangerous, explosive atmosphere occurs only rarely and then only for a short time.

## 16. Certificates

ZERTIFIKAT | CERTIFICATE | CERTIFICAT | CERTIFICADO | СЕРТИФИКАТ | 證書 | 인증서





## Zertifikat - Certificate

(1) **EU-Baumusterprüfbescheinigung**  
gemäß Richtlinie 2014/34/EU, Anhang III, Ziffer 6

(2) Geräte und Schutzsysteme zur bestimmungsgemäßen Verwendung in explosionsgefährdeten Bereichen - **Richtlinie 2014/34/EU**

(3) EU-Baumusterprüfbescheinigungsnr. **TÜV-A 20ATEX01113 X**

(4) Gerät:  
Typen: **Rührwerksantrieb mit Zonentrennflansch**  
**eco-Seal LIGHT eco-Seal PRO**  
**eco-Seal INOX eDRIVE**

(5) Hersteller: **PTM mechatronics GmbH**

(6) Anschrift: **Gewerbepark 1**  
**D-82281 Egenhofen**

(7) Die Bauart dieses Gerätes sowie die verschiedenen zulässigen Ausführungen sind in der Anlage zu dieser Baumusterprüfbescheinigung festgelegt.

(8) TÜV AUSTRIA SERVICES GMBH bescheinigt als notifizierte Stelle Nr. 0408 nach Artikel 17 der Richtlinie des Rates der Europäischen Gemeinschaften vom 26. Februar 2014 (2014/34/EU) die Erfüllung der grundlegenden Sicherheits- und Gesundheitsanforderungen für die Konzeption und den Bau von Geräten und Schutzsystemen zur bestimmungsgemäßen Verwendung in explosionsgefährdeten Bereichen gemäß Anhang II der Richtlinie.  
Die Ergebnisse der Prüfung sind in dem vertraulichen Prüfbericht TÜV-A 2020-TAD-000101 festgelegt.

(9) Die grundlegenden Sicherheits- und Gesundheitsanforderungen werden erfüllt durch Übereinstimmung mit  
**EN ISO 80079-36:2016 EN ISO 80079-37:2016**  
mit vorbehaltlicher Berücksichtigung der angeführten Anforderungen in Punkt 18 der Anlage.

(10) Falls das Zeichen "X" hinter der Bescheinigungsnummer steht, wird auf besondere Bedingungen für die sichere Anwendung des Gerätes in der Anlage zu dieser Bescheinigung hingewiesen.

(11) Diese EU-Baumusterprüfbescheinigung bezieht sich nur auf Konstruktion, Überprüfung und Tests des spezifizierten Gerätes oder Schutzsystems in Übereinstimmung mit Richtlinie 2014/34/EU. Weitere Anforderungen der Richtlinie können für das Herstellungsverfahren und die Inverkehrbringung dieses Gerätes oder Schutzsystems gelten. Diese sind von vorliegender Bescheinigung nicht abgedeckt.

(12) Die Kennzeichnung des Gerätes muss die folgenden Angaben enthalten:  
Siehe (15)



Wien  
Ort  
Place

23.11.2020  
Datum  
Date

Michael Reuschel  
Notifizierte Stelle 0408  
Notified Body 0408  
**TÜV AUSTRIA SERVICES GMBH**

Online Verification



FM INE EXS-ENG-02000  
Rev. 07  
ZTRK TÜV-A 20ATEX0113 X.docx  
Seite 1/4

**TÜV AUSTRIA SERVICES GMBH**  
Auszugsweise Vervielfältigung nur mit  
Genehmigung des TÜV AUSTRIA SERVICES  
GMBH gestatten!  
*The duplication of this document in parts is subject  
to the approval by TÜV AUSTRIA SERVICES  
GMBH*

Deutschesstraße 10  
1230 Wien / Österreich  
Tel.: + 49 711 722 336-18  
E-Mail: [explosionschutz@tuv.at](mailto:explosionschutz@tuv.at)  
Web: <http://www.tuv.at>



028177-20-1

Verifizierung nur auf Druck des TÜV AUSTRIA. This reproduction of this document is subject to the approval by TÜV AUSTRIA. 100%

## Certificate

- (1) EU type examination certificate  
in accordance with Directive 2014/34 / EU, Annex III, Section 6
- (2) Devices and protective systems for the intended use in potentially explosive areas  
- Directive 2014 / 34EU.
- (3) EU type examination certificate number **TÜV-A 20ATEX 01113 X**
- (4) Device: Agitator drive with zone separation flange  
Types: eco-Seal LIGHT      eco-Seal PRO  
          eco-Seal INOX      eDRIVE
- (5) Manufacturer: PTM machatronics GmbH
- (6) Address:                      Gewerbepark 1 D-82281 Egenhofen
- (7) The design of this device and its various permissible versions are specified in the appendix to this type-examination certificate.
- (8) TÜV AUSTRIA SERVICES GMBH as a notified body No. 0408 according to Article 17 of the Directive of the Council of the European Community of February 26, 2014 (2014 / 34 / EU), certifies the fulfillment of the basic safety and health requirements for the design and construction of devices and protective systems for their intended use in potentially explosive areas according to Annex II of the Directive.  
The results of the test are defined in the confidential test report TUV-A 2020-TAD-000101.
- (9) The basic health and safety requirements are met by:  
**EN ISO 800 79- 36: 2016 EN ISO 80079-37: 2016**  
subject to consideration of the requirements listed in point 18 of the annex.
- (10) If the sign "X" stands behind the certificate number, this indicates special conditions for the safe use of the device, named in the annex to this certificate.
- (11) This EU-Type Examination Certificate relates only to the construction, examination and testing of the specified equipment or protective system in accordance with Directive 2014 / 34 / EU. Further requirements of the directive may apply to the manufacturing process and the placing on the market of this device or protective system. These are not covered by this certificate!
- (12) The identification of the device must contain the following information: see (15)

## EU- Konformitätserklärung

### EU-Declaration of Conformity

<b>Hersteller:</b> <b>Manufacturer:</b>	PTM mechatronics GmbH Gewerbepark 1 D-82281 Egenhofen
<b>Produktbezeichnung:</b> <b>Name of Product:</b>	e-Drive
<b>Gerät, Produktbeschreibung:</b> <b>Description of Product:</b>	Rührwerksantrieb mit Zonentrennfansch

Das Konformitätsbewertungsverfahren gemäß RL 2014/34/EU wurde unter Beteiligung der folgenden benannten Stelle durchgeführt:

TÜV Austria Services GmbH  
Deutschstraße 10  
1230 Wien/Österreich  
Identifikations-Nr.: 0408

Baumusterprüfung nach Anhang III RL 2014/34/EU. Baumusterprüfbescheinigung: **TÜV-A 20ATEX01113 X**

**Gerätekenzeichnung:**  
**Device Marking:**

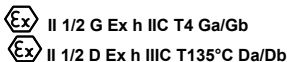

Die Konformitätserklärung bezieht sich nur auf die Konzeption und Fertigung der oben beschriebenen Geräte gemäß EU-Richtlinie 2014/34/EU in Übereinstimmung mit den harmonisierten Normen EN ISO 80079-36:2016 und EN ISO 80079-37:2016 "konstruktive Sicherheit".

Die zugehörige Bedienungsanleitung enthält wichtige sicherheitstechnische Hinweise und Vorschriften für die Platzierung und Inbetriebnahme der ECO-Rührwerke gem. RL 2014/34/EU.

Folgende harmonisierte Normen und Spezifikationen wurden bei der Entwicklung und Fertigung angewandt:

**EN 292-1 | EN 292-2 | DIN EN 1953:2010-09**

**ISO 13849-1:2006**

**ZH 1/406 | BGV D25 | BGV D15**

**DGUV Sicherheitsanforderungen für Stativ- und Hängerrührwerke**

**Maschinenrichtlinie**

**RL 2006/42/EG, Anhang II, 1.A**

**ATEX-Herstellerrichtlinie**

**RL 2014/34/EU**

Folgende harmonisierte Normen wurden bei der Entwicklung und Fertigung angewandt:

**DIN EN ISO/IEC 80079-34:2017**

**Anwendung von Qualitätsmanagementsystemen für die  
Herstellung von Ex-Produkten**

**DIN EN ISO 80079-36:2015**

**Teil 36: nichtelektrische Geräte für den Einsatz in explosionsfähigen  
Atmosphären „konstruktive Sicherheit c“**

**DIN EN ISO 80079-37:2015**

**Teil 37: nichtelektrische Geräte für den Einsatz in explosionsfähigen  
Atmosphären „konstruktive Sicherheit c“**

Egenhofen, den 19.05.2021

Carsten Angermeyer  
Geschäftsführer

Translation  
EU Declaration of Conformity

Manufacturer: PTM mechatronics GmbH  
Gewerbepark 1  
D-82281 Egenhofen

Name of product e-Drive

Description of Product: Agitator drive with zone separation flange

The conformity assessment procedure according to RL 2014/34 / EU was carried out with the participation of the following notified body:

TÜV Austria Services GmbH  
Deutschstraße 10  
1230 Vienna/Austria  
Identification number: 0408

Type examination according to Annex III RL 2014/34 / EU. Type examination certificate:

**TÜV-A 20ATEX01113 X**

Device Marking:

**Ex II 1/2 G Ex h IIC T4 Ga/Gb**  
**Ex II 1/2 D Ex h IIIC T135°C Da/Db**

The declaration of conformity only relates to the design and manufacture of the devices described above according to EU Directive 2014 / 34 / EU in accordance with the harmonized standards EN ISO 80079-36: 2016 and EN ISO 80079-37: 2016 "constructive safety".

The associated operating instructions contain important safety information and regulations for the placement and commissioning of the ECO agitators according to RL 2014/34 / EU.





PTM mechatronics GmbH  
Gewerbepark 1 | D - 82281 Egenhofen

Fon +49 8134 25 797 0 | Fax +49 8134 25 797 99

[info@ptm-mechatronics.com](mailto:info@ptm-mechatronics.com) | [www.ptm-mechatronics.com](http://www.ptm-mechatronics.com)

