

Drive and stirring technology for

PHARMA | FOOD | COSMETICS | CHEMICALS | AUTOMATION



Drum agitator for 2" tight-head drum



Stirrer drive:
eco-Drive
ATEX certification
Ex II 2 G Ex h IIC T5 Gb X
Ex II 2 D Ex h IIIC T100°C Db X

• Flexible traverse with range from
378mm/14.88in to 613mm/24.13in

Agitator shaft
V4A Edelstahl 1.4404

Pitch blade turbine
V4A stainless steel 1.4404
(glass bead blasted)



PITCH BLADE TURBINE
folded

for 2" tight-head drum openings



PITCH BLADE TURBINE
unfolded

WE GENERATE MOVEMENT IN SPECIAL ENVIRONMENTS.

Recommended combinations

Individual dimensions possible.

Dimensions in mm/in.

Agitator for 200l tight-head drum

Art. no.:

eco-Drive 1800 V2: 6003

Agitator shaft 730/28.74: 5097

Pitch blade turbine Ø200/7.87: 5215

Flexible traverse: 5089

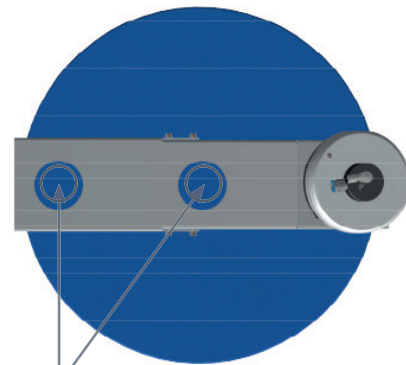
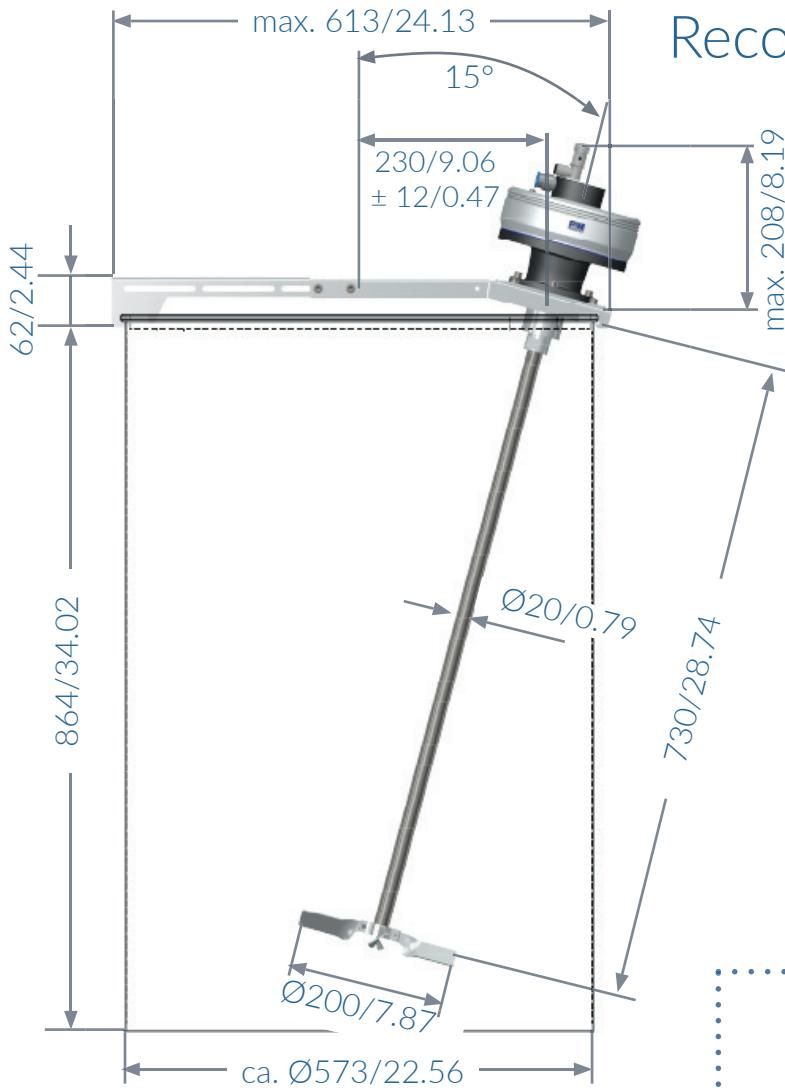

Bunghole

Agitator for 60l tight-head drum

Art. no.:

eco-Drive 900 V2: 6003

Agitator shaft 545/21.46: 5109

Pitch blade turbine Ø150/5.91: 5251

Flexible Traverse: 5089

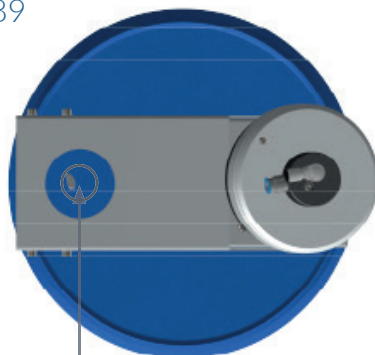

Bunghole

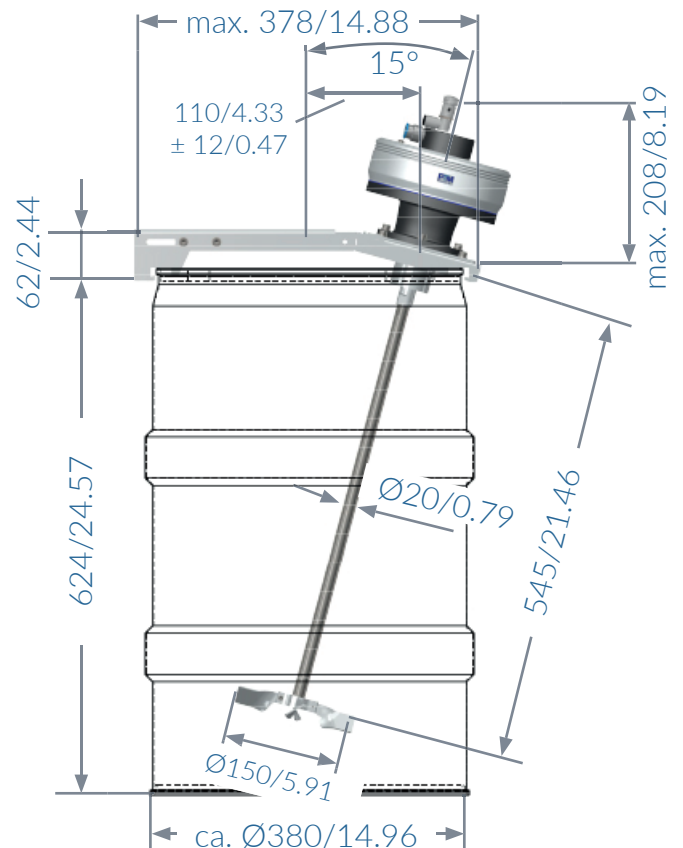

WE GENERATE MOVEMENT IN SPECIAL ENVIRONMENTS.